



Successful mission of TuPOD, an innovative CubeSat, a TubeSats deployer manufactured via Additive Manufacturing by CRP USA using Windform® XT 2.0 composite material

ABSTRACT

Small satellites provide a responsive alternative to larger, more expensive satellites. As demand grows, engineers must adapt these “nanosatellites” or CubeSats to provide new achievements and goals. One of these achievements is deploying TubeSats from International Space Station (ISS). TubeSats are cylindrical shape and are not compatible with normal CubeSats deployer platform (P-POD) on ISS, thus, an innovative nano-satellite, TuPOD (Tubesat-POD), was developed to address the challenge.

TuPOD inaugurated a new era for scientists wanting to use small, highly reliable satellites. It is the first complete 3D printed satellite launched from the ISS, made by CRP USA from CRP Technology’s proprietary material Windform® XT 2.0, the ground breaking carbon fiber reinforced composite 3D printing material known for its mechanical properties, developed with CRP USA. (shown in Figure 1)



Figure 1: TuPOD deployed © JAXA / NASA

OVERVIEW

The story of TuPOD began when a group of Brazilian Students needed to launch their TubeSat, TANCREDO-1, from ISS. They approached G.A.U.S.S. Srl (Group of Astrodynamics for the Use of Space Systems), an Italian company with close relationship to the University of Rome, to help them overcoming the challenge of launching their TubeSat from ISS.



GAUSS was faced with the challenge of designing an innovative system to deploy the first TubeSats into orbit that could act as both a satellite and release platform. GAUSS began the process of evaluating technologies that could produce a system with the capability to board and release two TubeSats that could meet the rigid mechanical properties for space applications while avoiding traditional tooling challenges. In that regard, GAUSS teamed up with Teton Aerospace, LLC (Tetonsys) in California, USA which has Bob Twiggs, founder of cubesat, as a co-founder. With the collaboration of GAUSS and Tetonsys, the TuPOD concept was developed.

The main objective of the TuPOD is to give TubeSats the possibility of release from ISS when presently there are no deployers or launchers for this type of satellites.

The final part was designed and built by Tetonsys with GAUSS guidelines and support from CRP USA and Morehead State University (MSU), for being integrated inside the J-SSOD system and released from the Japanese module “KIBO” at the ISS.

The two TubeSats launched using TuPOD were:

- TANCREDO-1, as part of the UbatubaSat Project, carried out by Brazilian students from “Escola Municipal Presidente Tancredo de Almeida Neves” together with INPE
- OSNSAT, developed by the Open Space Network, a Californian space company.

After around 83 hours after the initial release from the ISS, and after having flown into a slightly lower orbit than the ISS, the TuPOD deployed its on-board two TubeSats, TANCREDO-1 and OSNSAT. Then the TuPOD started transmitting a beacon signal (Morse code) for the Amateur Radio community on the frequency 437.425MHz with a variation of +/- 10KHz due to the Doppler shift. The satellite transmitted a small FM Morse beacon that lasted for 4 days until the primary mission was completed and the primary batteries depleted. TuPOD has de-orbited and burned up safely upon re-entry into Earth’s atmosphere.

DEVELOPMENT AND LAUNCH OF A CUBESAT / DEPLOYER

Designing and manufacturing a functional satellite which is a 3U CubeSat and at the same time a deployer of TubeSats proved to be challenging. Understanding the limitations with traditional manufacturing technologies, the opportunity to develop a unique system based on the use of Additive Manufacturing (AM) technologies was identified. Additive manufacturing technologies in Aerospace applications has presented both opportunity and challenges to engineers and scientist in the field. The ability to produce parts and components using additive manufacturing technologies hold promise in both metals and plastics. Whereas, traditional subtractive manufacturing technologies can be restrictive in design development and material selection.

Additive manufacturing technology is often faster than designing and producing a tool for traditional manufacturing technologies. Furthermore, 3D Printing has given engineers more flexibility in the timeline to make design improvements and being able to think outside of limitations caused by traditional tooling. This choice made it possible to substantially reduce the costs and has been very convenient in terms of timing when compared to traditional production methods. The unique properties of AM Windform® XT 2.0 material have allowed system optimization that successfully withstands the design requirements due to space limitations and the extreme conditions of the launch. The TuPOD successful mission marks a great example of both scientific advance and international cooperation.



The requirements to build the mothership were stringent. The TuPOD is a 3U CubeSat satellite, fully 3D printed out of Windform® XT 2.0 by CRP USA, with 4 external Anodized Aluminum rails (40% weight of an equivalent of an aluminum structure). Stewart Davis, Director of Operations at CRP USA, “The deployment device for most CubeSats is called a P-Pod. This device is square, and can only deploy structures that fit within its constraining devices that are the 4 corners. The rails that were placed on TuPOD were in part to allow a "round peg to fit properly in the square hole” ”.

The TuPOD needed to be designed like a 3U CubeSat parallelepiped, but to hold two TubeSats 3.5” dia x 5” long while using the CubeSat launch infrastructure with JAXA on the ISS. It was needed to create an interface between a cylindrical structure as TubeSat is, and a parallelepiped structure as 3U CubeSat is. It was possible through the use of Additive Manufacturing and the Windform® XT 2.0 material.

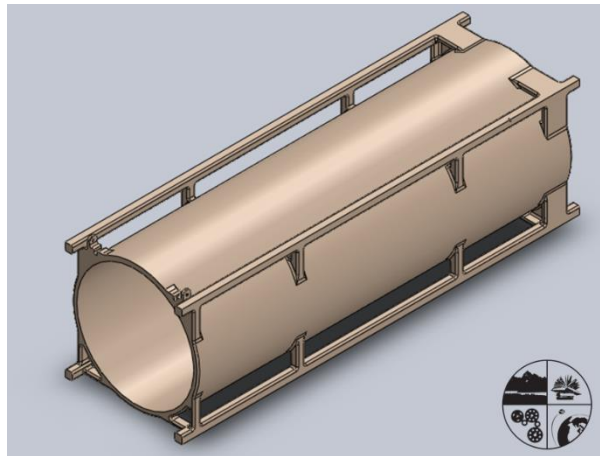
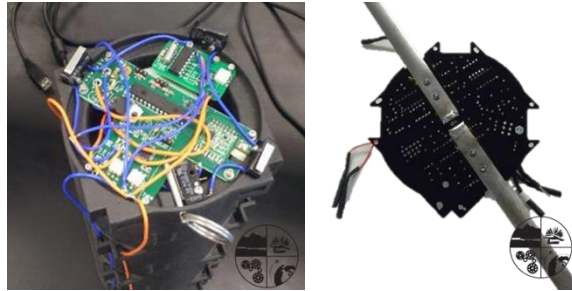

Figure 2: Initial design of the TuPOD, Courtesy of Tetonsys

Thanks to this specific kind of deployer, two TubeSats (a new type of Nanosatellites, cylindrically-shaped, not much bigger than an ordinary beverage can) were released into Space for the first time. To date, there wasn't any launch possibility for this class of small satellites: with the TuPOD project, a new and affordable launch opportunity for the users of this new type of satellite has been created.

Another issue to address was the creation of a special shape for electronics. Originally, the plan was to use PocketQube electronic boards developed by Morehead State University, KY, USA (Figure 3). But the problem was the complexity of wiring between multiple boards in such a compact space. Tetonsys took advantage of the electronic layout used in the PocketQube electronic boards and created a single board (Figure 4), which conducted the same performance but in a smaller area and placed at the lower side of the TuPOD. Chantal Cappelletti, project manager at GAUSS: “Internally, TuPOD is a smooth cylinder with no cavities except for a separated single board located in the lower part of the cylinder. The single board houses the pocketQube electronics and it is appropriately separated from the satellite to avoid any damage during the TubeSat integration operation”. The single board turned out to be a brilliant dual usage design.



Figures 3 and 4: Special electronics integration and design, Courtesy of Tetonsys

In TuPOD, the satellite BUS design was complex but simple in manufacturing, since the part could be produced straight from a 3D CAD file, with no tooling required. By utilizing additive manufacturing technology, a 3D CAD model is designed on the computer, then “printed” in 3D. To optimize the part for final-use case, design changes can be made to the part and produced (or printed) again and again with little concern for casting, as tooling and secondary machinery is not necessary.

While the challenge of designing and manufacturing of the mothership (TuPOD), as a single-part was addressed with the use of additive technology, the next step was to find a material that could meet the rigid mechanical properties required for space applications. A variety of additive technologies available on the market could produce the TuPOD design, however, the material properties were too weak and inconsistent with the density of the fussed structured.

During the evaluation process and design review, GAUSS opted for Windform[®] XT 2.0 a strong, highly functional material, specifically designed for the additive manufacturing using laser sintering technology, with application in Aerospace Industry.

“The carbon fiber-reinforced composite 3D printing material Windform[®] XT 2.0 was introduced to representatives of GAUSS by Professor Twiggs of Morehead State University and Co-Founder of Tetonsys” stated Chantal Cappelletti. “Professor Twiggs used the Windform material in a project involving a small satellite and Windform[®] XT 2.0 performed above expectations. That’s the reason why we decided to accept the Windform[®] XT 2.0 for TuPOD project.”



Figures 5: Final design of the TuPOD using Windform XT 2.0, Courtesy of Tetonsys.



According to Amin Djamshidpour, designer of TuPOD and co-Founder of Tetonsys: “ Using Windform® XT 2.0 material in the 3D manufacturing of TuPOD was one of the best decisions we have made. Windform® XT 2.0 is an electrically conductive material and machine-able. During the prototyping phase and even the final manufacturing, we got into multiple situations that we needed to drill the part or make small modifications to the 3D printed structure and working with Windform® XT 2.0 gave us the ability to do so.”

Prof. Twiggs: "This unique design was only possible with the 3D printing by CRP USA and the space qualified Windform® XT 2.0 material. The rapid response, low cost and quality were the key factors in making this a successful mission."

The TuPOD project represented clear challenges for CRP USA and the additive manufacturing technology. At the same time, the manufacturing of such a design without CRP material and manufacturing process, seems impossible. After hours of analysis and design by Tetonsys, the final CAD model was ready to be manufactured. Designed using the Windform® XT 2.0 material properties, the CAD file was sent to CRP USA and the part produced.

The result was an additive manufactured, single-part with unique features, shown in Figure 6, (special shape for batteries, electronics, and release door) that was sent to Tetonsys for integration of electronics and make it ready for Environmental testing. When Tetonsys received the TuPOD, immediately noticed the difference in the quality of construction versus other additive technologies and impressed with the fact that the TuPOD came as a ready-to-use part, no additional manufacturing required. This saved the team both time and money.



Figures 6: Special Shape for batteries and electronics, Courtesy of Tetonsys

After completion of electronic board integration and multiple functional test performance, the TuPOD was sent to Morehead State University for final vibration and thermal vacuum testing.



Figure 7: final vibration and thermal vacuum testing, Courtesy of Morehead University

During the course of TuPOD qualification, two series of full environmental testing was performed on TuPOD and at each level multiple functional testing and deployment testing performed to assure the integrity of structure, electronics and the overall system.

To perform the final integration of TubeSats into the modership, TuPOD was shipped to GAUSS in Italy.

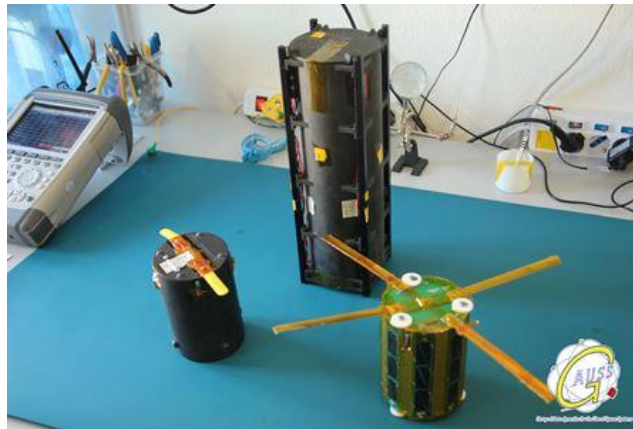

Figure 8: Integration of the TubeSats into the TuPOD by the GAUSS team in Rome. Courtesy GAUSS Srl



Figure 9: Last phase of the TubeSats integration. Courtesy GAUSS srl

Then the TuPOD was brought to Japan for its integration into the CubeSat deployer J-SSOD (JEM Small Satellite Orbital Deployer) at the Tsukuba Space Center of JAXA (Japan Aerospace Exploration Agency) in Ibaraki Prefecture, by a GAUSS and JAXA team.

The deployer J-SSOD, containing TuPOD, together with other nanosatellites, was installed inside the autonomous spacecraft H-IIB, named “KOUNOTORI 6”, for the HTV-6 mission, to deliver supplies to the International Space Station (ISS).

The Japanese launcher HTV-6 was sent from the Yoshinobu Launch Complex, Tanegashima Space Center, to the International Space Station (ISS).

“KOUNOTORI 6” was captured by the ISS’ robotic arm (Canadarm-2, 17.6 meters-long) and berthed to the ISS. After having been attached to the ISS, the spaceship remained berthed for six weeks (in this time period the astronauts performed spacewalks to replace some of the ISS batteries with the new ones that the HTV-6 carried).

The TuPOD was then deployed, with the Japanese astronauts’ help, from the ISS Japanese Experiment Module “KIBO”.



Figure 7: TuPOD deployed © JAXA / NASA

TANCREDO I and OSNSAT were released from the TuPOD satellite/deployer about three days after the launch into orbit of the TuPOD, as soon as the TuPOD was distant enough from the ISS.

The astronauts manually set the launch, and accomplished the task using the deployment device JAXA “J-SSOD” (Small Satellites Orbital Deployer), specifically designed to release on orbit small satellites.

Once in space, the TuPOD itself and TANCREDO-1 transmitted telemetry data, which have been received and decoded by radio amateurs from all over the world.

“TuPOD mission,” – stated Chantal Cappelletti, Project Manager GAUSS “was scheduled to work up to one week, and it worked more than the expected time. Since the system was not equipped with solar cells, it was impossible to survive more than a few days. We can consider the TuPOD mission itself a great success since it sent message for more time than expected”.

"During the mission," Cappelletti added, “Windform® XT 2.0 has passed all the flight qualification tests in complex systems as the International Space Station is. This achievement, unimaginable until recently, opens many perspectives on the possibility of using Windform® materials for space applications.

In particular, GAUSS Srl is more than satisfied with Selective Laser Sintering technique and considers Windform® family of high performance composite materials one of the disruptive revolutions in the small satellites arena. Plus, GAUSS is using them for new projects”.

From a technical point of view, the TuPOD represents an innovation, since its structure has been completely 3D printed. The mission used cutting-edge technology and the TuPOD itself represents an innovative space product, developed to launch a new type of pico-satellites, such as TubeSats.

Stewart Davis stated, “Unlike many technologies that were originally developed for Aerospace that are then adapted to Motorsports, Windform® XT 2.0 is a purely Motorsports drive material.” Windform® was originally developed by CRP USA’s partner CRP Technology based in Modena, Italy, for use in Formula One Racing, first in the wind tunnel and then on the track. Mr. Davis commented, “Our team was very happy for Tetonsys, GAUSS,



Morehead State University, JAXA, the TANCREDO team, and OSNAT on their successful mission. We look forward to continuing to produce components for our racing partners, with a material that is both proven on the track and carries an added bonus of Space Flight heritage. TuPOD is an international project and Windform® family of high-performance composite materials has global nature. In fact, we cover four continents: Europe, South America, North America and Asia ”

CONCLUSION

This case study shows how the use of Windform® composite XT 2.0 material, originally developed for the motorsports industry, is now finding many uses in space exploration .

Applying theoretical and practical knowledge were key to the design and production of the TuPOD. The combination of the additive laser sintering technology, Windform® XT 2.0, and CRP USA resulted in a single-part, high-performance smallsat and at the same time deployer, that meet the rigid material properties required for space applications.

CRP Windform® XT 2.0 material combined with its laser centric additive manufacturing capabilities has create a new realm of possibilities for satellite designers to go beyond standardized requirements and limitations. Windform materials are used extensively in high-performing sectors due to their mechanical properties, and CRP USA is the ideal technological partner for utilizing Windform® and Additive Manufacturing.

Based in Mooresville, North Carolina, CRP USA resides in the heart of the southern industrial and manufacturing hub, and is surrounded by growing Aerospace community. With more than a decade of experience in 3D Printing and Advanced Manufacturing, CRP USA works alongside key industry leaders to manufacture functional prototype and end-use components from their Windform® family of high-performance composite materials.

Prof. Bob Twiggs, founder of CubeSat and co-founder Teton Aerospace, LLC: "TuPOD unique design was only possible with the 3D printing by CRP USA and the space qualified Windform® XT 2.0 material. The rapid response, low cost and quality were the key factors in making this a successful mission."