

# COOLING TECHNOLOGIES FOR ELECTRIFIED AVIATION

Lars Enhardt, DLR Institute of Electrified Aero Engines, Cottbus



# DLR sites and employees



- More than 12.000 employees working at in **51** research institutes and facilities at **30** sites
- Institute of Electrified Aero Engines (EL)** was founded 2020 in Cottbus



# Research Profile of the DLR Institute in Cottbus

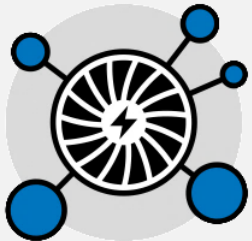

**Component  
Technologies**

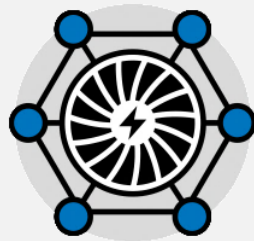

**Architecture and  
Integration of  
Propulsion System**



**Aeronautical  
Requirements and  
Control of Propulsion  
System**



**Environmental  
Impact and Sensor  
Technology**



**Test Facilities  
and Infrastructure**

# Content

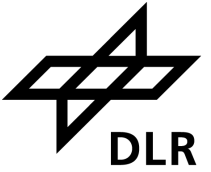

**Thermal Management in Electrical Propulsion Systems**

**Component Technologies (Examples)**

**System Architecture (Examples)**

**Experimental Facilities**

**Wrap-Up**

# Thermal Management in an Electric Propulsion Topology

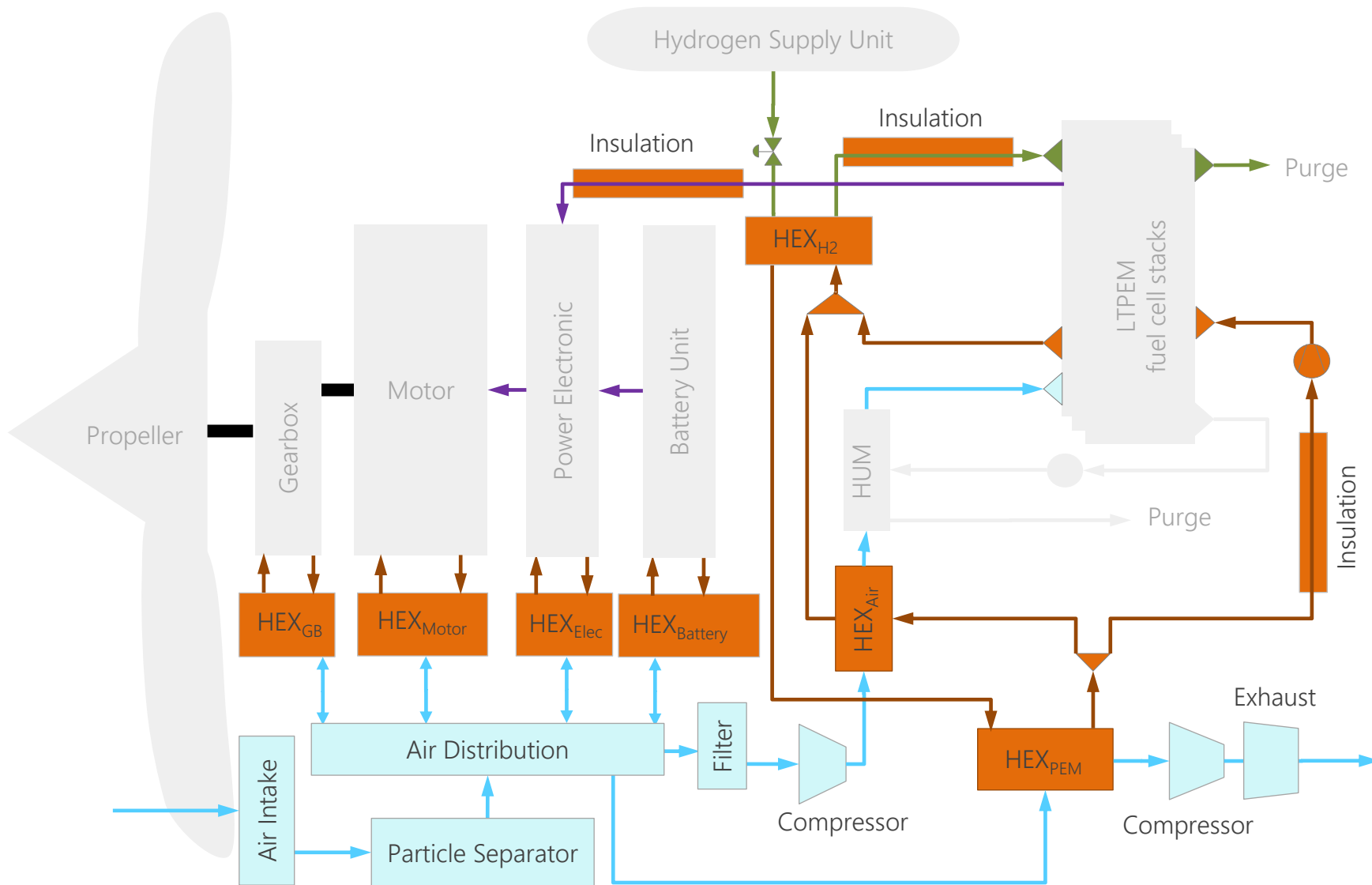
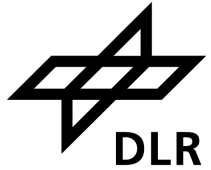

## Legend

- Air Management
- Thermal Management
- Air
- Coolant
- H<sub>2</sub>: Hydrogen
- Electric Wires
- HEX: Heat exchanger
- HUM: Humidifier

# Thermal Management Studies

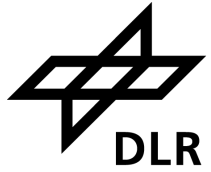
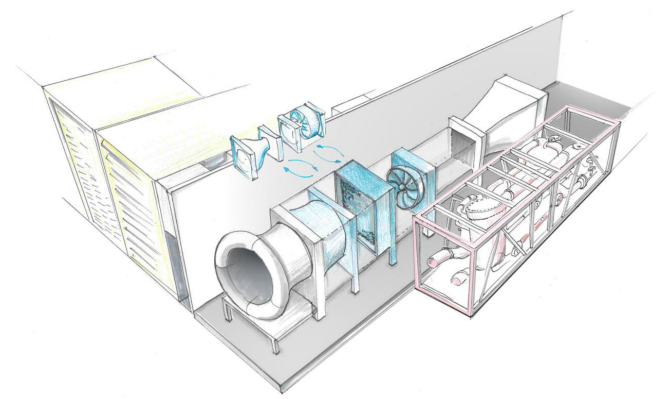

## Ongoing work

### Analytical Investigation

HEX design and optimization  
Sizing and optimization within overall powertrain  
HEX integration design  
Degradation prediction

### Numerical Investigation

Air duct simulations  
Heat rejection  
Impact on drag  
Multi-Phase flow

### Experimental validation

Air duct: drag & heat  
Fan – HEX interplay  
Liquid Cooling loop  
TMS validation

- Investigate the heat problems of electrified aero engines
- Generate robust basis of knowledge for design and integration
- Prediction of heat transfer vs losses (drag, energy consumption)



# COMPONENT TECHNOLOGIES

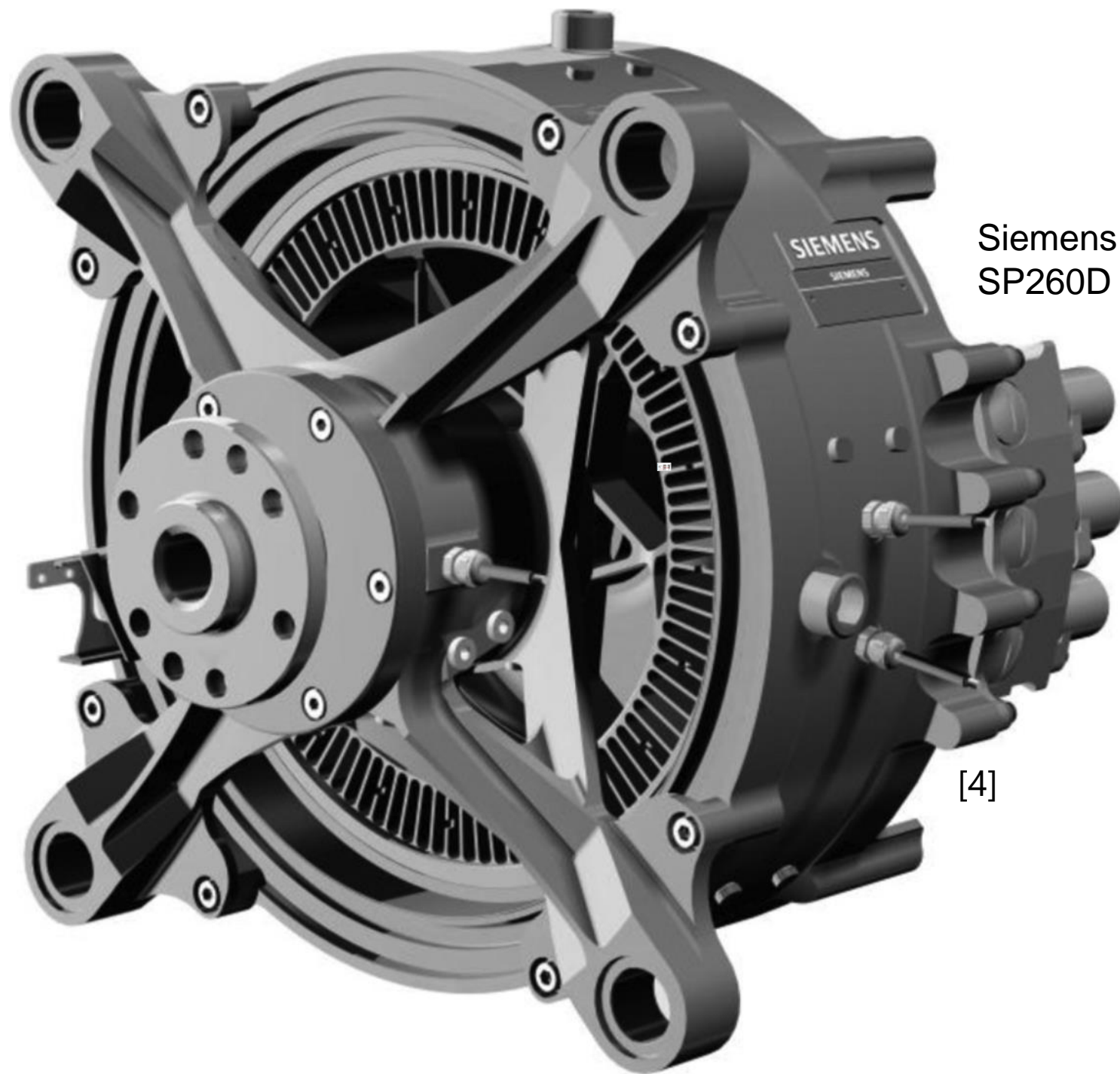

Siemens  
SP260D

[4]

# Heat Sources of Electric Machine [1]

## ■ Permanent Magnet Synchronous Machine PMSM (exemplary)

### ■ Loss Types:

- Copper Losses (DC/AC)
- Iron Losses (AC)
- Magnet Losses (AC)
- Mechanical Losses

### ■ Heat Sources:

- Stator Core
- Winding Packs/Conductors
- Rotor Core

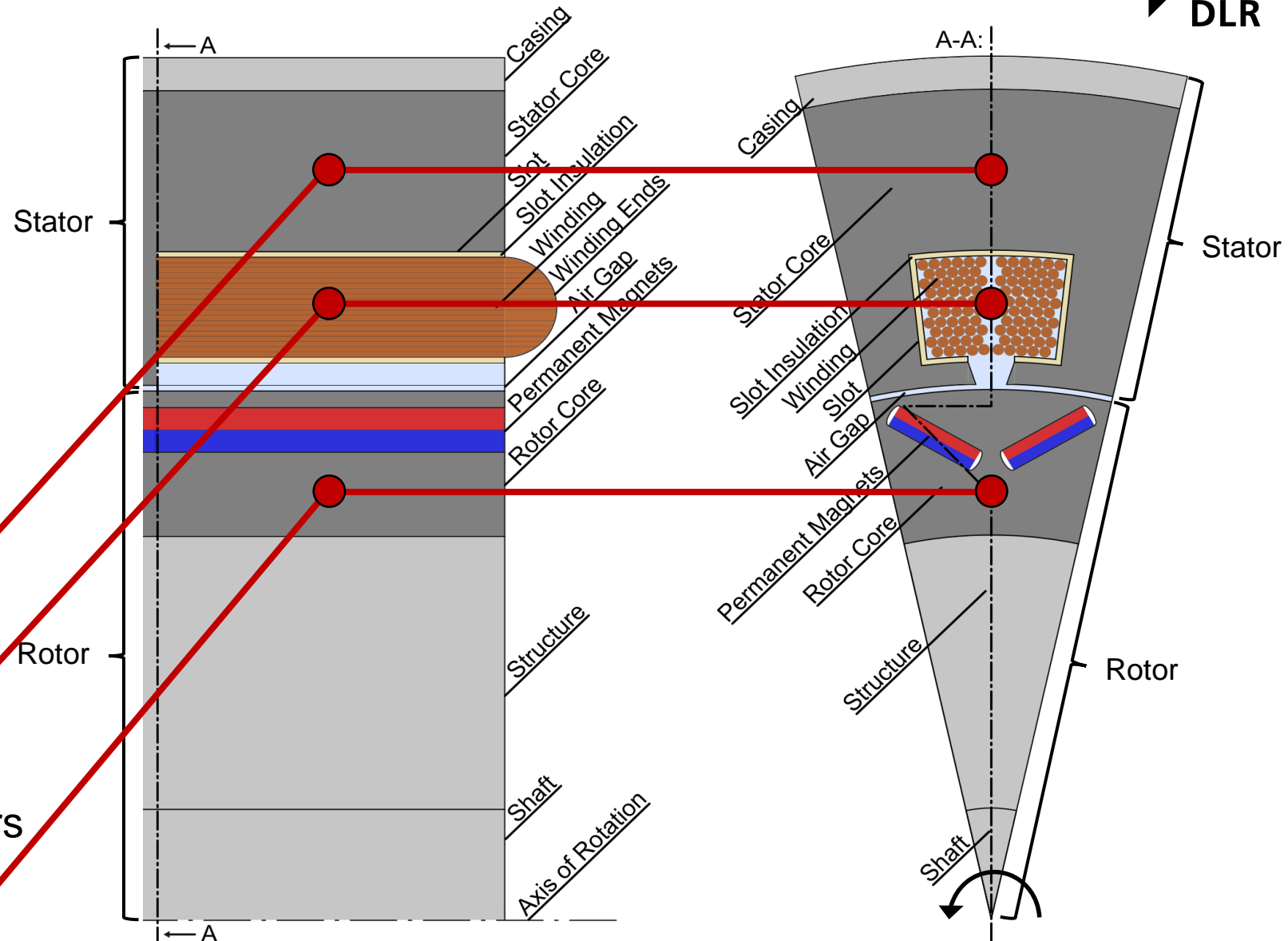

# Ongoing Research on Electric Machine Cooling [1]

## Tasks

- Analytical Modeling of Cooling Concepts
- Parameter-based Evaluation

## Findings

- High Heat Dissipation Potentials of **Direct Cooling Technologies**
- Best Cooling Effectivity for **Channel Cooling** and **Hollow Conductor Cooling**

## Ongoing Work

- Modeling & Optimization of various Cooling Concepts
- Efficiency Calculation including Cooling Circuit
- Numerical/Experimental Validation

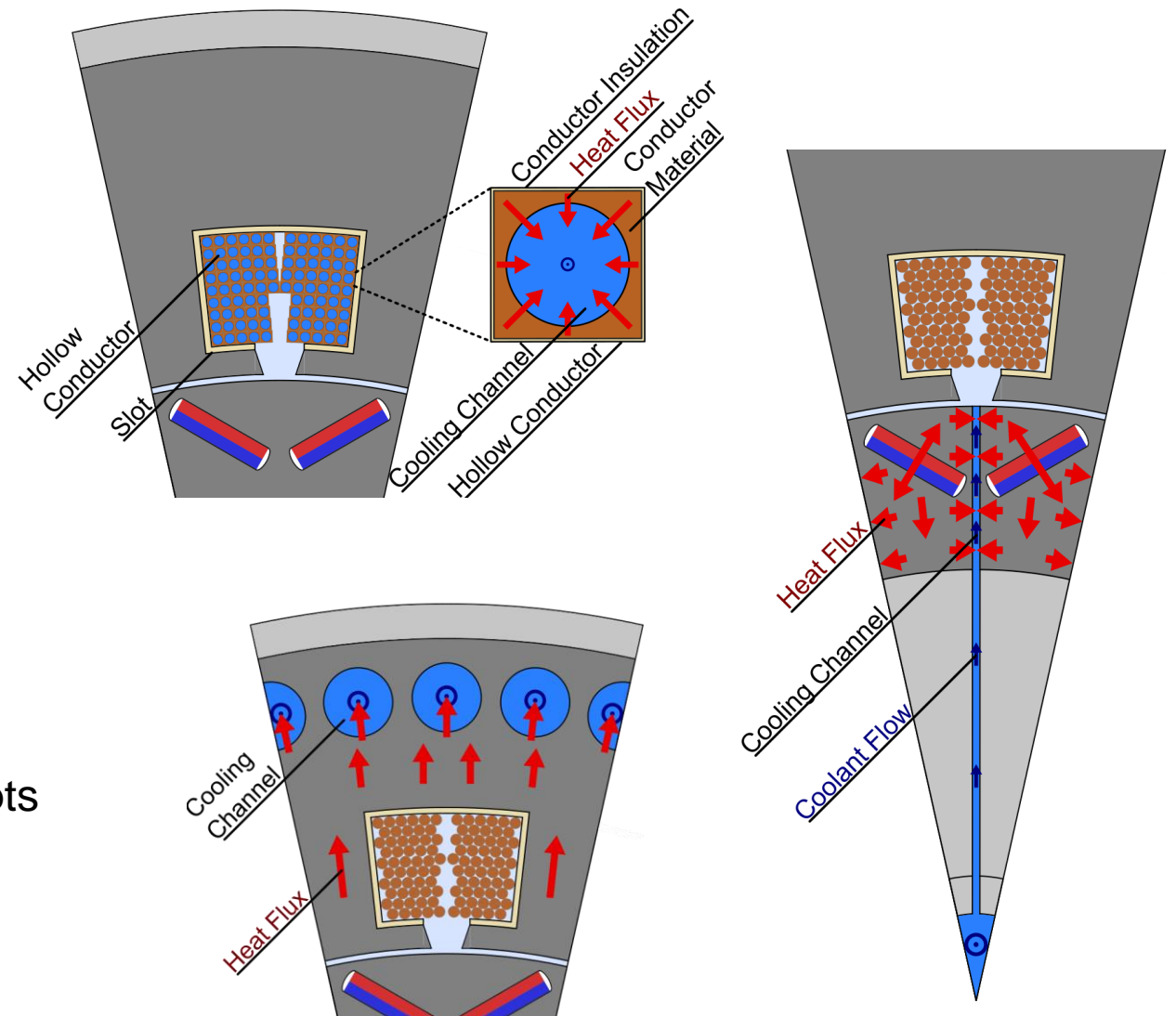

# Compact & Lightweight Heat Exchanger Development



## Preliminary Design

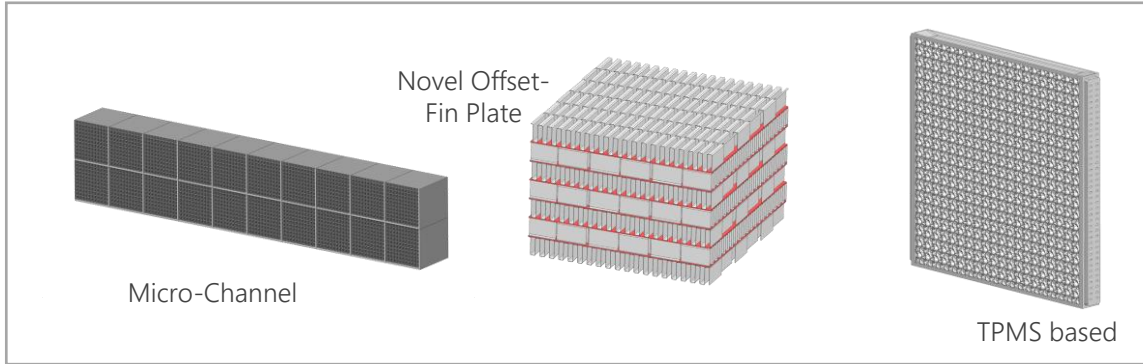

## Detailed Design

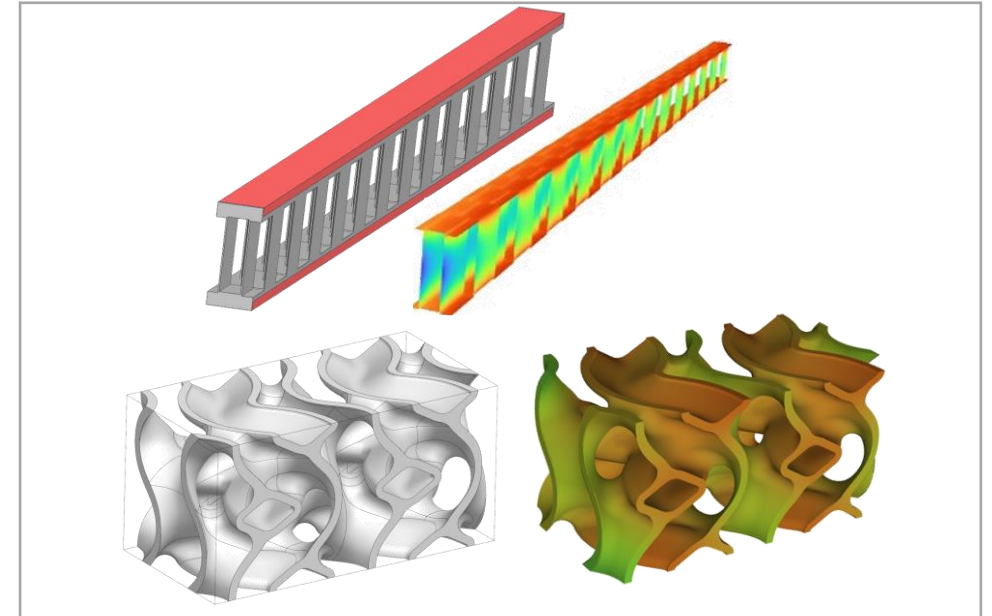

## Prototype Development

- Size variation for scale-up study
- Conventional and additive manufacturing
- Design optimization for manufacturability and quality



## Test and Validation

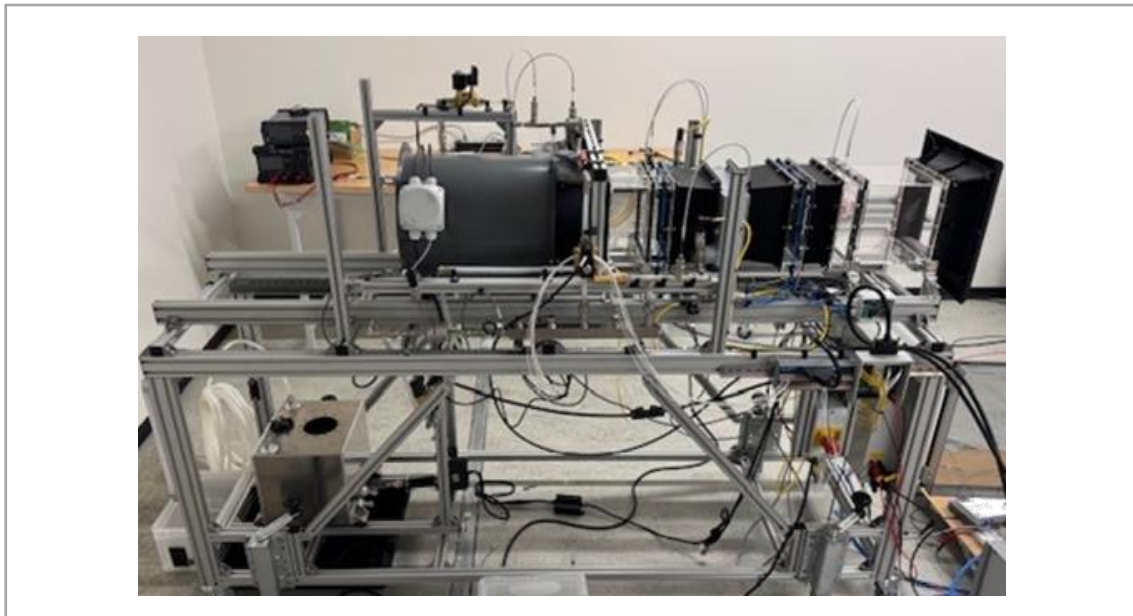

# Modeling [2]

$$\sin(x) \cdot \cos(y) + \sin(y) \cdot \cos(z) + \sin(z) \cdot \cos(x) = 0$$

## – Modeling the TPMS Gyroid Structures

- Surface modeling offers parametric design and modifications for integrated channels
- Size: 200mm X 200mm X 20mm plate for core HX with additional bulkheads for coolant distribution

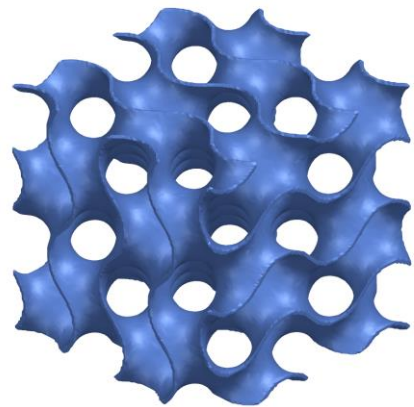

### Implicit Modeling

Very accurate

Long calculation time

Problem with thin Walls

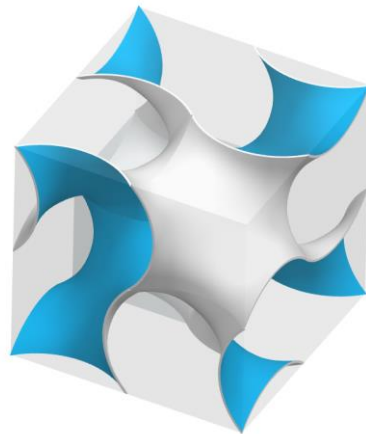

### Surface Modeling

Smooth Surface

Good Performance

No limitations of wall thickness

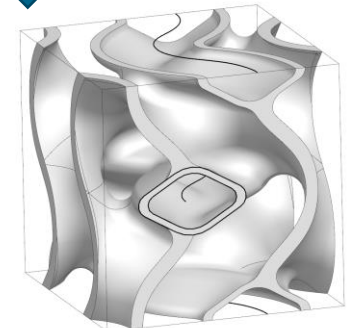
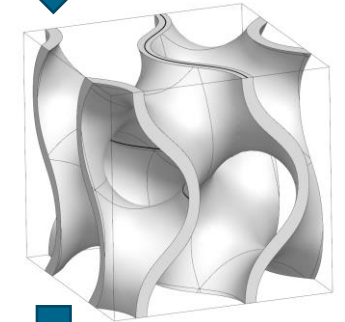
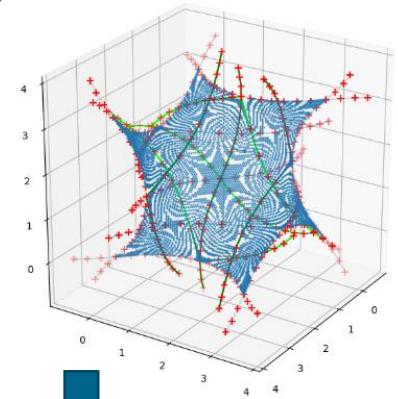
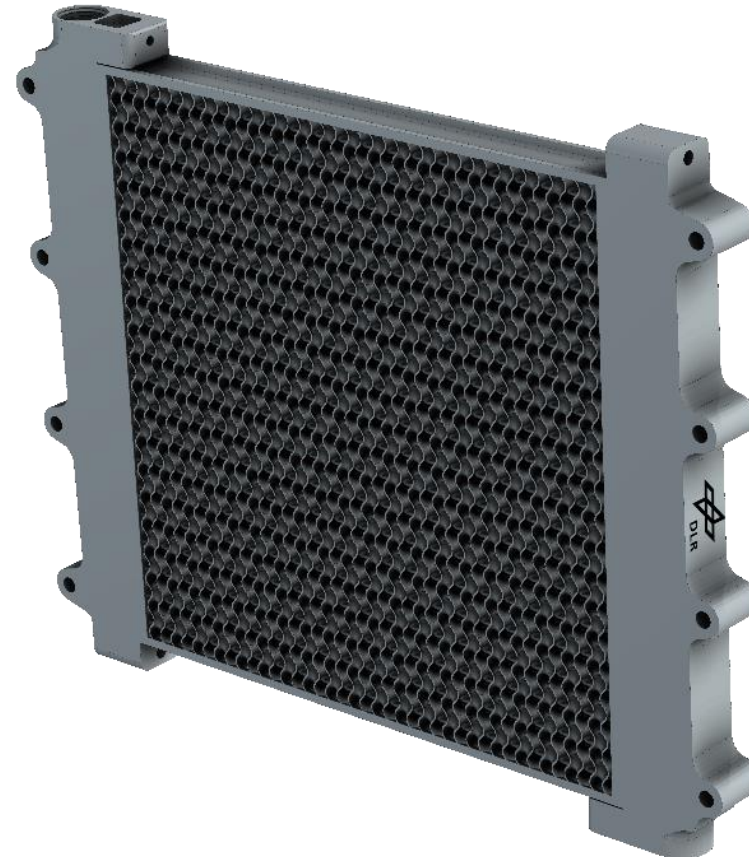

# Prototype Development [2]

## – Additive Manufacturing

- 3D laser sintering
- An iterative process involving design modifications (e.g. thin walls) and printing quality
- Surface quality can be improved through heat treatment and shot peening

Source: WJW

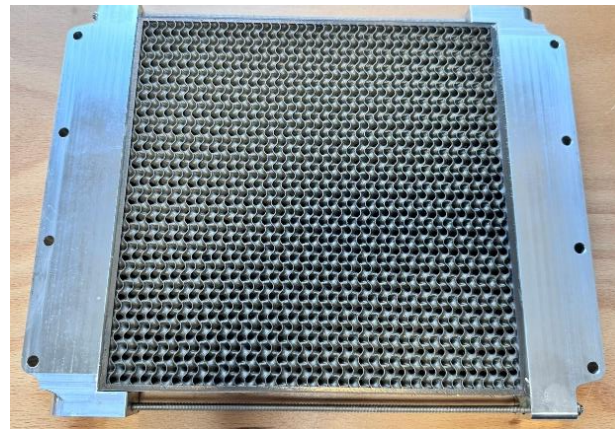
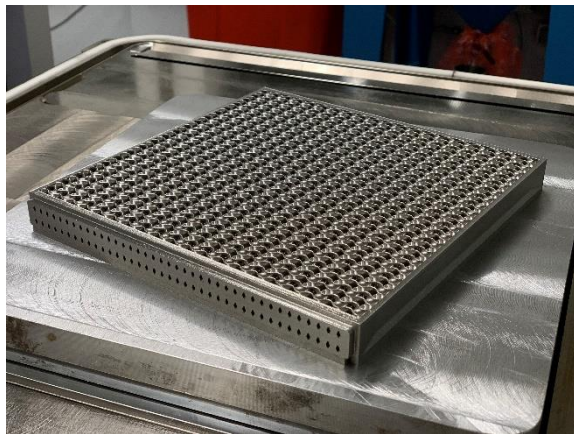

Source: BAM



# SYSTEM ARCHITECTURE

# Modelling and Simulation of Electrified Topologies

## Development of suitable models

### Fundamentals

- Selection and evaluation of propulsion system topologies
- Development, analysis and validation of static/dynamic models characterizing components of the propulsion system
- Derivation of performance maps for component models
- **Thereby:** Focus on electrical components i.e. thermal management, fuel cell systems, inverter

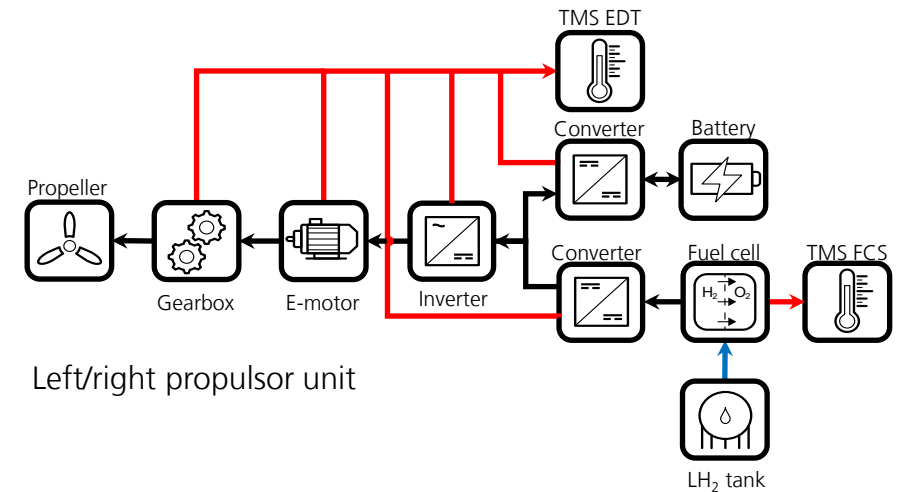

### Goal

- Creation of the basis for a holistic **preliminary sizing** of suitable electric and hybrid-electric propulsion system architectures as well as the **performance analysis** and **prediction**

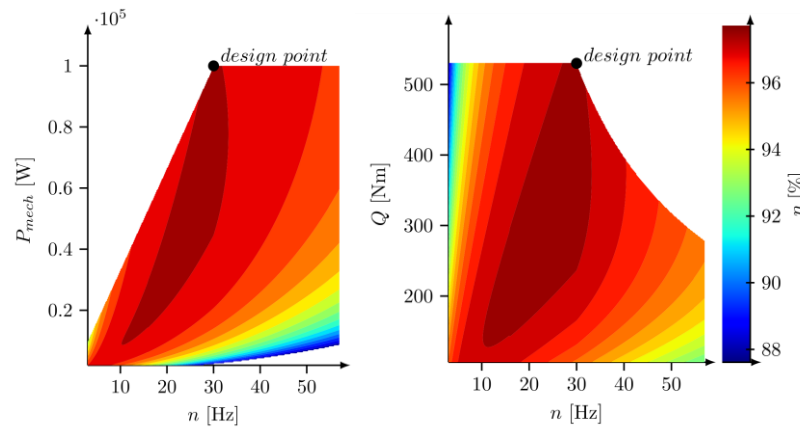

Source: V. Bahrs et al., DLRK 2022

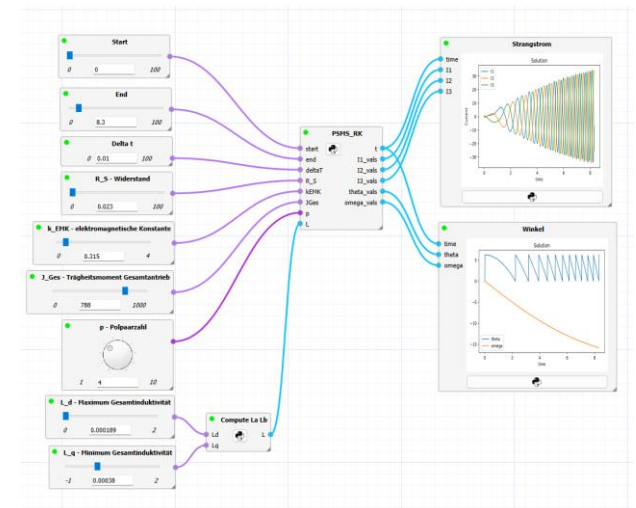

# Simulation of flow in a duct [3]

## □ Porous Media

- Reduces computational load
- Captures essential flow features

## □ Mitigate Flow Separation

- Use guidance features
- Analyze wall curvature effects

## □ Optimize Geometry Design

- Tilted heat exchanger
- Adjust cross-sections

## □ Pressure Drop Analysis

- Evaluate different configurations
- Use experimental data

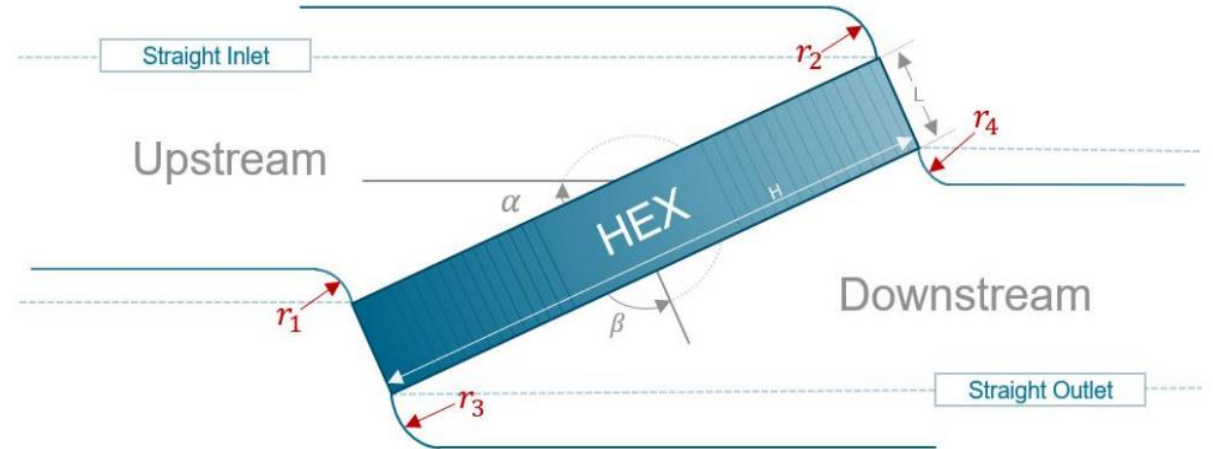

Figure 1 : Sketch of the geometric configuration of air cooling line with tilted heat exchanger of lateral length  $L$ . The radii ( $r_1, r_2, r_3, r_4$ ) represent the upstream and downstream wall curvatures relative to the HEX and ' $\alpha$ ' as the angle of alignment.

# Simulation of flow in a duct [3]

## □ Porous Media

- Reduces computational load
- Captures essential flow features

## □ Mitigate Flow Separation

- Use guidance features
- Analyze wall curvature effects

## □ Optimize Geometry Design

- Tilted heat exchanger
- Adjust cross-sections

## □ Pressure Drop Analysis

- Evaluate different configurations
- Use experimental data

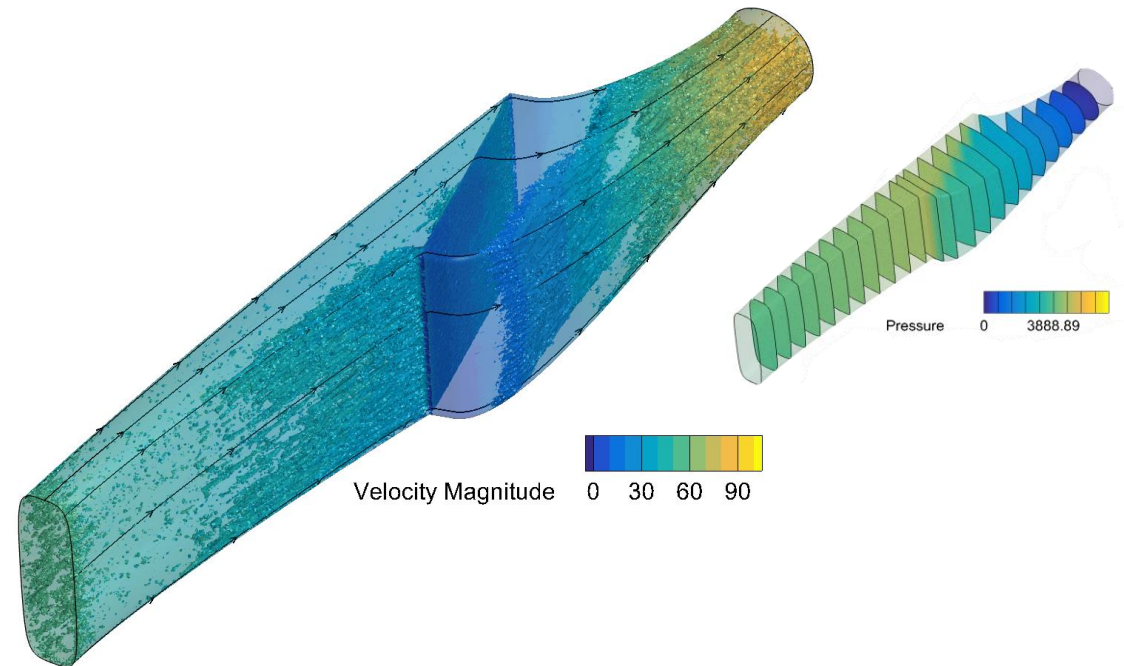



# EXPERIMENTAL FACILITIES

# Optical measurement capabilities

- Quantification of thermodynamics scalar field and fluid flow fields by use of optical measurement techniques
  - Background oriented Schlieren – density and temperature fields
  - Infrared thermography – surface temperature fields
  - Particle Tracking – Velocity fields

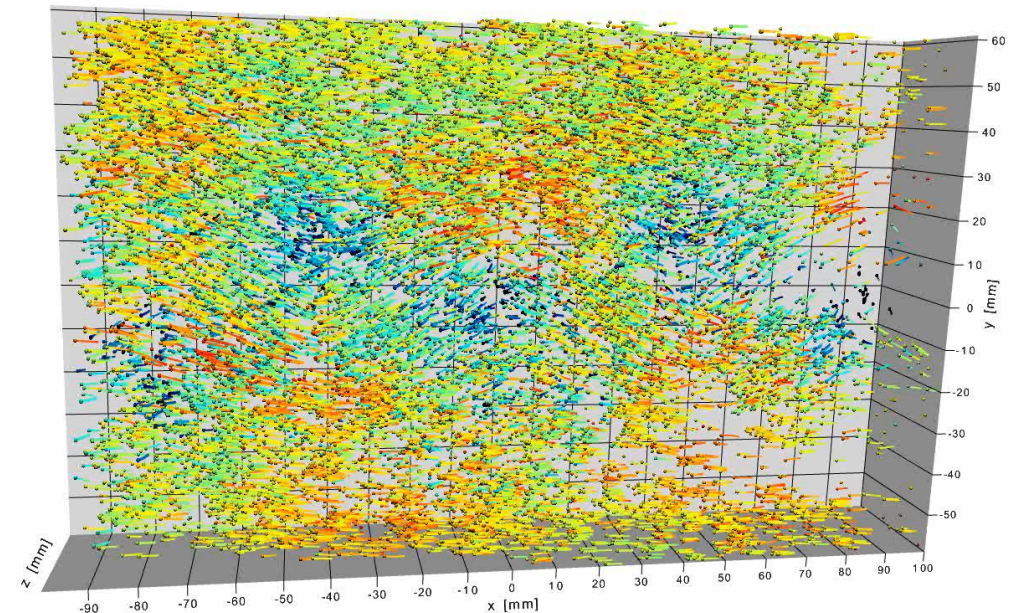
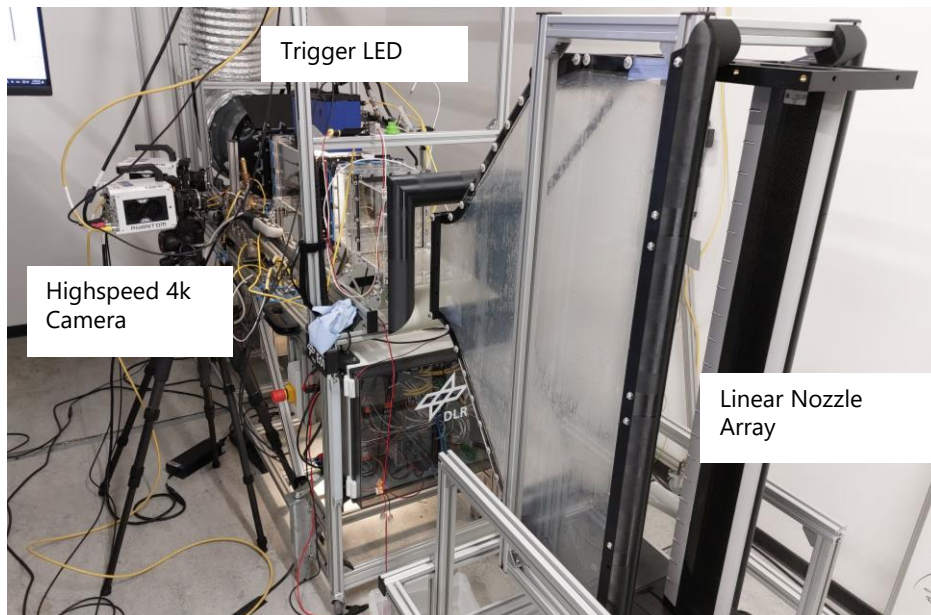
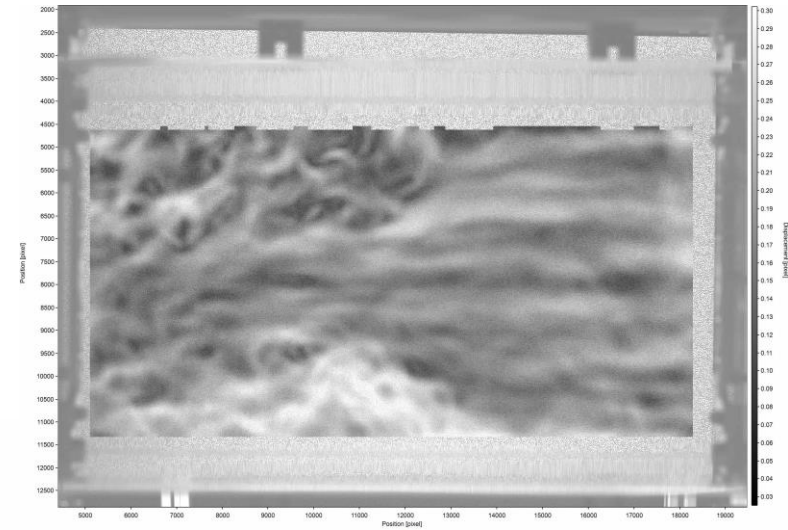

# Outlook: TMT Nacelle Integrated Cooling Environment

- Investigation of internal flow
  - In-/Outlet open
  - No propeller, no external flow
  - Heat source up to 1 MW
- Focus on experimental access for versatile measurement techniques
- Various configurations
  - Segments exchangeable
  - Single-Fan, Tandem (Windmilling)
  - HEX-FAN assembly
  - Duct geometry influences

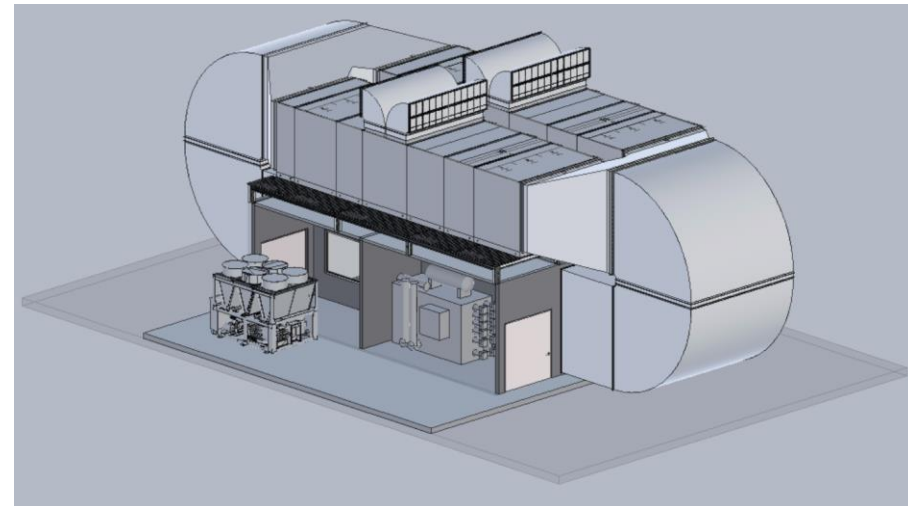
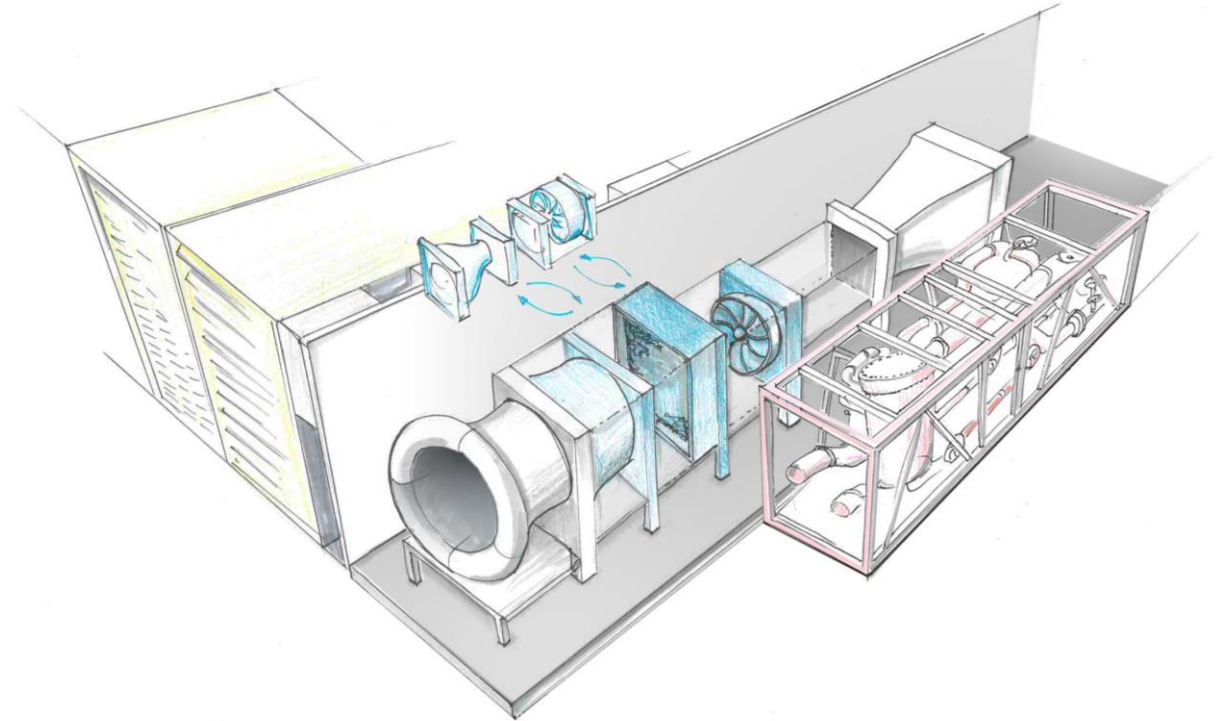

# WRAP-UP

## Thermal management

- Major challenge on the way to electrified aero engines
- Research is conducted on
  - Component technologies
  - System architecture and –integration
  - Whole propulsion system pre-design
  - LCA, durability, fault detection
  - Control
  - Batterie management incl. TMS
  - Sensor technology for monitoring
  - Certification
  - Environmental impact

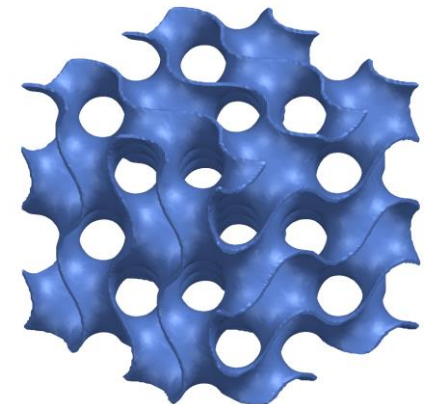
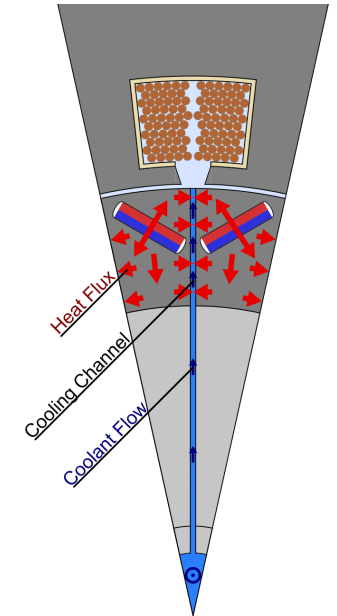
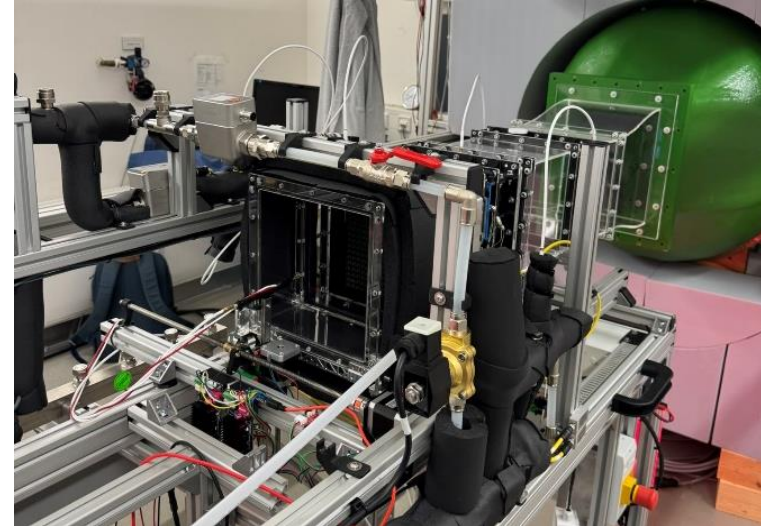

# References



- [1] F. Heise and S. Kazula, Analytical Modeling and Parameter-Based Evaluation of Cooling Technologies for MW-Class High Specific Power Electric Motors in Electrified Aircraft Propulsion Systems, 2024 IEEE International Conference on Electrical Systems for Aircraft, Railway, Ship Propulsion and Road Vehicles & International Transportation Electrification Conference (ESARS-ITEC), Naples, Italy, 2024, pp. 1-8, doi: 10.1109/ESARS-ITEC60450.2024.10819808
  
- [2] Chetan K. Sain and Stefan Kazula, Comparative Assessment of Compact Air Heat Exchangers for Fuel Cell-Powered Electric Aircraft, AIAA 2024-3831, Session: Modeling Insights for Electric Aircraft Design III, 2024, <https://doi.org/10.2514/6.2024-3831>
  
- [3] P. Singh, S. Merbold, S. de Graaf, "Numerical investigation of wall curvature effect on air cooling lines with tilted heat exchanger for Electrified Aero Engines" NNFM, Springer 2025
  
- [4] Goraj, R. (2018), "Novel coupled model for power loss prediction in a record-breaking electric aircraft motor", Aircraft Engineering and Aerospace Technology, Vol. 92 No. 3, pp. 345-354. <https://doi.org/10.1108/AEAT-12-2017-0278>

Contact:  
<https://www.dlr.de/el>  
[lars.enghardt@dlr.de](mailto:lars.enghardt@dlr.de)



**THANK YOU!**

**ANY QUESTIONS?**